

PRESSURE TESTING SYSTEMS AND SOLUTIONS

Our Expertise - Pressure



Our Products and Solutions

	Calibration	Valve Testing	Customised
hydraulic 3000 bar 300 bar	Hydraulic Comparator 1500 bar	Safety Valve Test Bench	Multi Port Test Skid Inst. Valves & Fittings
pneumatic 160 bar 100 bar 60 bar	Pneumatic Comparator 60/100/160/300 bar	Ball/Gate/Globe Valve Test Bench	Automatic Gauge Saver Test Skid
	Electronic Pressure Controller	Control Valve Test Bench	Hydro-Pneumatic Test Panel
vacuum 0 -760 mmhg	Ultimate Vacuum Comparator -745 mmhg	Breather Valve Test Bench	Potable Pressure Source Unit

Test & Measuring Instruments

THERMAL IMAGER
POWER QUALITY ANALYZER
UNDERGROUND PIPE AND CABLE LOCATOR

ADVANCED CALIBRATION TOOLS

ELECTRONIC PRESSURE CONTROLLER

MODEL-EVC



- Precise Electronic Pressure Controller
- Set Pressure through Keypad
- Very high resolution with 0.25% accuracy
- Range : 1/5/15/30/100/500...3000 psi
- Power requirements - 12 – 24 Vdc, 250 mA

ULTIMATE VACUUM COMPARATOR

MODEL-UVC



- Automatic Vacuum Generation
- Max Vacuum up to -745 mmHg
- Precise regulator for fine-tuning
- Quick stability within seconds
- Power requirements - 230 VAC

SMART RANGE OF PRESSURE COMPARATOR



MODEL-SRPC-P

- Automatic Pressure Generation
- Fully Pneumatic
- Precise regulator for fine-tuning
- Quick stability within seconds
- Available Models - 60, 100 & 160 Bar

MODEL-SRPC-H



- Automatic Pressure Generation.
- Hydraulic Pressure up to 1500 Bar.
- Pneumatically Operated.
- Requires 6 – 8 Bar Air.
- Quick stability within seconds.

PRODUCTION SERIES FOR GAUGE MANUFACTURERS

5-PORT GAUGE TEST BENCH



- Automatic Pressure Generation
- Inbuilt Pneumatic/Hydraulic Source
- Precise regulator for fine-tuning
- Quick stability within seconds
- Customised Pressure Range

3/4/5 POINT CALIBRATION UNIT



- Customised Set points
- Quick Pressure steps with Just Push/Hand valve
- Pneumatically/Hydraulic options
- Quick stability within seconds.

VALVE TEST BENCHS

SAFETY VALVE TEST BENCH



Clamping	Hydraulic	Quick Clamping	Manual	Quick Clamping
Size	1/2" to 4"	1/2" to 4"	1/2" to 8"	1/2" to 8"
Test	Hydro & Pneumatic	Hydro & Pneumatic	Hydro & Pneumatic	Hydro & Pneumatic
Range	Up to 150 bar	Up to 100 bar	Up to 230 bar	Up to 230 bar
Pressure	External Supply	External Supply	External Supply	External Supply

HYDRO-PNEUMATIC TEST PANEL WITH HYDRAULIC CLAMPING STATION

- In-bulit Hydro-Pneumatic Pressure Source
- Gas Booster: 200/300/400 bar
- Hydro Booster 200/300 bar
- Bladder Accumulator
- Hydraulic Clamping Station
- Valve Size: up to 4"/8"/12"
- Pop Test, Leak Test, Back Pressure Test
- Software for Automatic Report Generation



Safety Valve Analyzer Software

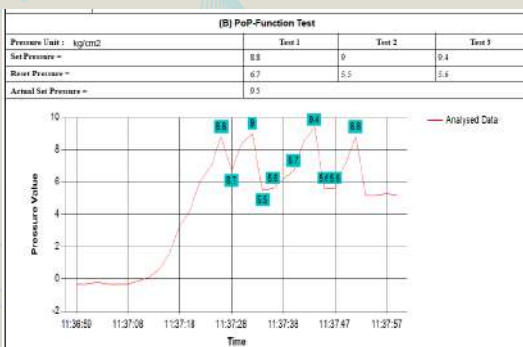

Digital Bubble Counter



Accessories

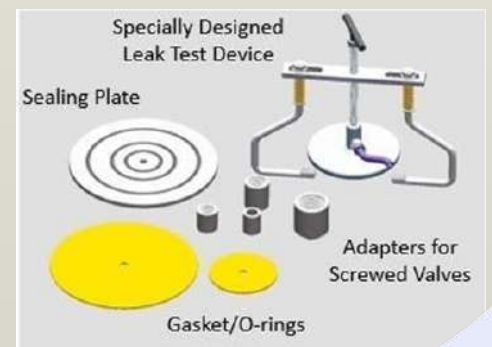

VALVE TEST BENCHS

UNIVERSAL VALVE TEST BENCH

- For Ball/Gate/Globe valves
- Sizes up to 4"/8"/12"
- Hydraulic Clamping Station
- Bottom 3-Jaw clamping for Seat Test
- Top Clamping for Shell Test
- Hydro Test Panel with Hydro Booster
- Pre-filling pump for Fast Water Filling

Valve Analyzer Software:

- Automatic Test Report generation with Graph for Seat Test and Shell Test



CONTROL VALVE TEST BENCH

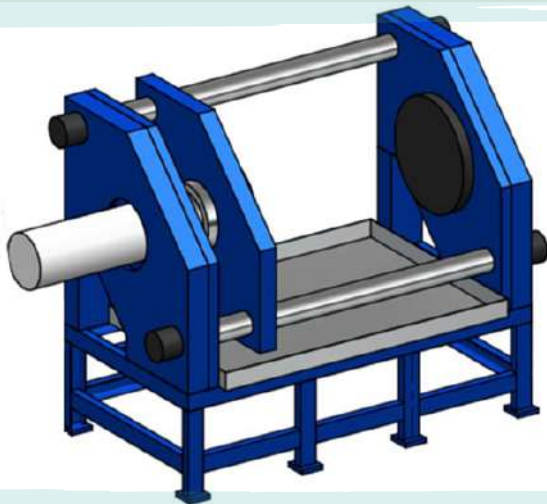

- Horizontal Valve Test Bench
- Sizes up to 4"/8"/12"
- Hydraulic Clamping Station
- Quick and Easy Mounting
- Hydro Test Panel with Hydro Booster
- Pre-filling pump for Fast Water Filling
- Easy Control Panel

Valve Analyzer Software:

- Automatic Test Report generation with Graph for Seat Test and Shell Test

BREATHER VALVE TEST BENCH

- Inbuilt Vacuum-Pressure Source
- **Software:** Automatic Test Report generation with Graph for
- Max. Pressure and Vacuum



MODELS	Portable	Economy	Big Size
Size	1/2" to 4"	1/2" to 8"	1/2" to 24"
Range	Vacuum -23 Inhg to 2 bar	Vacuum -23 Inhg to 2 bar	Vacuum -23 Inhg to 2 bar

CUSTOMIZED SOLUTIONS

PORTABLE PRESSURE SOURCE UNIT

MEDIA	HYDRAULIC	PNEUMATIC	
PUMP	Hydro Booster	Gas Booster	Compressor
INPUT	6-8 Bar Air	6-8 Bar Air/N2	230 VAC
RANGE	up to 1500 bar	up to 400 bar	up to 300 bar



TEST SKID - INSTRUMENTATION VALUES & FITTINGS



Automatic Gauge Saver Testbench

- Auto-clamping with pneumatic cylinder
- No Threading - No Thread Damage
- In-built Pneumatic Pressure Source 200 bar
- Superior Fine tuning - Precise Regulation
- Fastest Production Gauranteed

Multi-Port Testbench

- 5 Ports for simultaneous testing
- In-built Hydro/Pneumatic Pressure Source
- Pneumatic up to 6000 psi
- Hydro up to 30000 psi
- Fastest Production Gauranteed

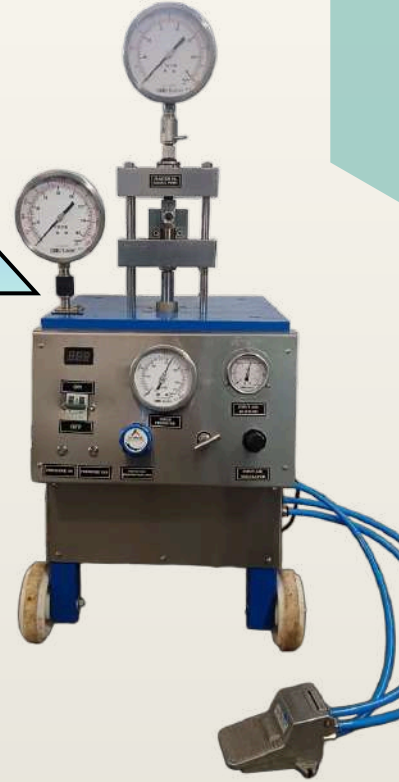

OTHER PRODUCTS

THERMAL IMAGER



- PRECISE TEMPERATURE MEASUREMENT
- HIGH RESOLUTION IMAGING
- LONG BATTERY LIFE
- RUGGED DESIGN

KRYKARD

POWER QUALITY ANALYZER

- SOLUTIONS FOR ADVANCED POWER QUALITY MONITORING & ANALYSIS
- MEASURE VOLTAGE, CURRENT, FREQUENCY,
- POWER (KW, KVA, KVAR), POWER FACTOR,
- ENERGY VALUES,
- HARMONICS, FLICKER FOR DETAILED ANALYSIS.



UNDERGROUND CABLE - PIPE LOCATOR



- MOST USEFUL TOOL
- LOCATE. AVOID. TRACE
- MAP BURRIED PIPE & CABLE
- MEASURE DEPTH
- CABLE & PIPE AVOIDANCE PRIOR EXCAVATION
- CABLE ROUTE TRACING
- NO PERIODIC CALIBRATION REQUIRED



BEST SELLER

OUR PARTNERS



OUR CUSTOMERS

INTERNATIONAL



DOMESTIC



Certified ISO 9001:2008



Email - techmarkengg@gmail.com

CONTACT NUMBERS -

+91 9081814783 | +91 7228814783

www.techmarkengg.in

Corporate Office Address -

314, Vihav Supremus, Beside Iskon Heights Gotri Road, Vadodara, 390021, Gujarat, India

Workshop Address -

K - 43, Gorwa BIDC Estate, Beside Jyoti SwitchGear, Gorwa, Vadodara - 390016, Gujarat, India